

Lerner Robotic Arm

Design Report 1

Cole Pace: Project Manager and Prototype Lead

Joel Gisleskog: Research Lead

**Caleb Lamca: Manufacturing Lead, Co Design Lead, and
Fundraising Lead**

Kaitlyn Davis: Finance Lead and Documentation Lead

**Colin Donnellan: Development Lead, Co Design Lead, and
Testing Lead**

Fall 2025-Spring 2026



Steve Sanghi College of Engineering

Project Sponsor: Dr Zachary Lerner

Faculty Advisor: Dr. Dante Archangeli

Instructor: Dr David Willy

DISCLAIMER

This report was prepared by students as part of a university course requirement. While considerable effort has been put into the project, it is not the work of licensed engineers and has not undergone the extensive verification that is common in the profession. The information, data, conclusions, and content of this report should not be relied on or utilized without thorough, independent testing and verification. University faculty members may have been associated with this project as advisors, sponsors, or course instructors, but as such they are not responsible for the accuracy of results or conclusions.

EXECUTIVE SUMMARY

This report details the progress and results of the first design phase for the waist mounted robotic arm project sponsored by Dr. Zachary Lerner. The goal of this report is to document the team's research, design decisions, and preliminary analysis that define the foundation for the device's development. Work completed includes background research, requirement definition, benchmarking, literature review, mathematical modeling, and initial concept selection supported by engineering analysis.

The report begins by outlining the motivation and objectives of the project, creating a lightweight, low-profile robotic arm capable of providing active gravity compensation for stroke survivors. Customer and engineering requirements were established through discussions with the sponsor and research on user needs. Critical targets include achieving a total system weight under 2 kg, torque outputs around 10-11.5 N*m at the hip, and 4.5 N*m at the elbow, three active degrees of freedom, and sufficient battery life for extended daily use. These requirements formed the quantitative basis for subsequent design and modeling decisions.

Research within the design space involved a literature review of robotic actuation methods of safety standards, materials, and biomechanics. Benchmarking examined existing rehabilitation and wearable robotic arms to compare functionality, form factor, and comfort. Mathematical modeling used inverse dynamics to estimate motion requirements, resulting in an angular velocity of 1.62 rad/s for natural reaching motion and torque values consistent with the engineering goals.

Two main design concepts were developed and evaluated: a direct-drive configuration with motors at each joint and a transmission-based configuration with motors mounted at the waist. Using a decision matrix that considered comfort, safety, range of motion, complexity, and ease of use, the team selected the transmission design as the preferred concept. Supporting calculations determined that the CubeMars AK45-36 motor met torque and speed requirements, while circular cross-section link geometry minimized bending stress and improved stiffness-to-weight ratio.

The report concludes with the initial CAD model of the direct drive design, which integrates revolute joints, fiber-reinforced 3D-printed links, and waist-mounted actuation. Future work will focus on prototype fabrication, testing for torque accuracy, motion smoothness, and user comfort, and refining control methods for improved gravity compensation. Overall, this report establishes the analytical, mechanical, and conceptual groundwork for building and validating the first functional prototype next semester.

Table of Contents

Contents

Disclaimer.....	3
Executive Summary.....	4
Table of Contents.....	5
1 Background.....	6
1.1 Project Description	6
1.2 Deliverables.....	6
1.3 Success Metrics.....	7
2 Requirements.....	7
2.1 Customer Requirements (CRs).....	7
2.2 Engineering Requirements (ERs).....	9
2.3 House of Quality.....	9
3 Research Within Design Space.....	9
3.1 Benchmarking.....	9
3.2 Literature Review.....	9
3.3 Mathematical Modeling.....	16
4 Design Concepts.....	20
4.1 Functional Decomposition.....	20
4.2 Concept Generation.....	21
4.3 Selection Criteria.....	22
4.4 Concept Selection.....	22
5 Conclusions.....	24
6 References.....	25

1 BACKGROUND

1.1 Project Description

Strokes are the leading cause of upper limb disability; survivors often report loss of mobility in one arm which limits daily use. Our hope is to develop a robotic arm which could assist a client's arm so that they can move their arm with ease of use. The robotic arm will be mounted at the waist, low-profile, lightweight, and provide active gravity compensation. The end effector will be attached to the elbow. The project sponsor is Dr. Zach Lerner.

Our budget is a generous 4000 dollars, and W.L gore is largely responsible for the funding. We plan to raise at least 400 dollars as this is the fundraising minimum (10%), however we hope to raise much more.

We believe our project is important as there are over 795,00 people each year in the US who experience a stroke. Around 6,3 million people are living with stroke-related consequences in the US, and some studies suggest 40-70% of survivors are affected by arm paresis (weakness) initially, and among those around half have little function in the following 6 months. We want to help those less fortunate than ourselves and believe that helping survivors regain their independence and ability is a great cause. Additionally, although our design is focused on helping those with upper limb disability from strokes, we hope our design can help anyone with impairment in their arms.

1.2 Deliverables

The main deliverables for this project include both physical prototypes and supporting design and analysis work. The outcome should clearly demonstrate a functioning waist-mounted robotic arm that provides active gravity compensation, is low profile and supports the elbow joint.

We plan to create a SolidWorks design for the full robotic arm system, including all parts, linkages, and motors. From there we will make engineering drawings and part lists which will be used for manufacturing and assembly. Working prototypes will be built from this model we will first try to replicate the ability of the arm with a rough mockup using cheaper materials however as we go into later prototypes we will use 3d printed carbon fiber and machined parts to get the best possible product.

Once we have built our first prototype we will see what works and what doesn't through physical testing an analysis, we will then go back to our cad model to modify anything that needs to be changed and we will reiterate this process until we our happy with our final design and it has met our success metrics.

1.3 Success Metrics

To define our success, we must assess what we want the robotic arm to be cable of the robotic arm must successfully support the users arm and provide smooth gravity compensation. The robotic arm must be lightweight and should allow the user to comfortably rest their arm by their side.

We will judge success based on how well our final design performs and to what degree they meet our design requirements through analysis and testing. Functionally, the arm should produce enough torque at the elbow to balance the weight of the forearm and the hand. We can check this through engineering calculations from our kinematic model and testing prototype's ability to hold the arm in different positions.

The arm should stay under a specified weight limit to maintain the low-profile description. SolidWorks will be used to measure the weight of the arm by using material properties, and we will verify the strength and stiffness using finite element analysis before we build our parts. Once the first prototype is made, we can weigh it and compare reality to simulation.

Energy efficiency and control are also key. The motors should use as little power as possible while still providing smooth and responsive motion. We can test this by measuring current draw and comparing how different motor setups (direct drive vs. transmission) perform.

Finally, overall comfort and natural movement will be checked by testing the prototypes to see if the elbow cup rests comfortably. If the robotic arm meets these requirements the project can be considered a success

2 REQUIREMENTS

2.1 Customer Requirements (CRs)

The primary customer requirements for the wearable robotic arm were identified through discussion with the project sponsor, Dr. Zach Lerner, and analysis of the target users (stroke survivors with limited upper-limb mobility). The most critical requirements are Range of Motion and Safety, both rated highest in importance. This device must allow natural arm movement while supporting the elbow through active gravity compensation. Safety ensures that the user is protected from excessive joint torque, pinch joints, or electrical hazards during operation. Comfort and Ease of use are also key factors, as the device will be worn for extended periods and must not restrict the user's daily activities. A Low-Profile design ensures minimal obstruction and promotes confidence in public use, while Durability guarantees long-term reliability under repeated mechanical loading. Lastly, Cost is considered to maintain affordability for both research and potential clinical applications.

These requirements directly reflect the needs and experiences of the intended users. Comfort and usability prioritize user well-being, while safety and range of motion ensure that the device functions as a true assistive aid. By balancing cost and durability, the team aims to produce a lightweight practical prototype that satisfies both the sponsor's research objectives and real-world feasibility. Collectively, these customer requirements serve as the foundation for translating user expectations into quantifiable engineering goals.

2.2 Engineering Requirements (ERs)

The engineering requirements translate the customer's needs into quantifiable design targets that can be measured and verified. The robotic arm will feature 3 Degrees of Freedom (DoF) to allow natural arm and

elbow motion while supporting necessary rehabilitation movements. To maintain comfort and reduce fatigue, the total system Weight is constrained to under 2 kg, with mass distributed near the waist to minimize user load. Torque Speed performance will target 60°/s to match realistic human joint motion speeds during lifting tasks. For endurance, Battery Life is specified to exceed 8 hours, ensuring the device can function for an entire therapy session or daily use period without frequent recharging.

Manufacturability and material quality are also defined quantitatively. Manufacturing Cost must remain below \$1,000, and both Component and Material Quality are rated at engineering levels suitable for safety and mechanical integrity under load. Additionally, Degrees of Freedom, Weight, and Torque Speed correspond directly to user comfort, range of motion, and ease of use, while Battery Life and Durability influence reliability and long-term satisfaction. These parameters provide concrete targets for design validation and testing, ensuring each engineering decision supports the primary customer objectives. The quantified metrics serve as performance benchmarks for prototype evaluation and future optimization.

2.3 House of Quality (HoQ)

		Degrees of Freedom	Quality of Components	Quality of Materials	Manufacturing Cost	Torque Speed	Battery Life	Weight	Correlation			
			pos	neg	pos	pos	neg	pos	Positive	pos		
									Negative	neg		
			pos		pos							
			pos	pos		pos						
			neg	pos		neg	pos					
			pos	pos	pos	pos	pos	pos				
Relative Weight (%)	Customer Weights	Customer Requirements	Engineering Requirements						Benchmarking			
			Degrees of Freedom	Quality of Components	Quality of Materials	Manufacturing Cost	Torque Speed	Battery Life	Weight	Poor	Adequate	Excellent
11	4	Comfortable	3	3	3	1	3	3	9		C	AB
22	5	Range of Motion	9	3	3	1	1	1	1	A	B	C
10	5	Safety	3	9	9	1	9	1	3			ABC
10	2	Cost for Consumer	3	9	9	9	3	3	3	AC	B	
5	3	Durability	1	9	9	1	1	1	9		B	AC
5	4	Ease-of-use	9	3	3	1	9	3	3	BC	A	
22	3	Low-Profile	3	1	3	3	3	9	9	ABC		
Technical Requirement Units			N/A	\$	\$	\$	o / s	Hours	lbs			
Technical Requirement Targets			4	<1400	<1000	<1000	60	>8	<2			

Figure 1: House of Quality

3 Research Within Your Design Space

3.1 Benchmarking

For benchmarking, the group decided to look at four different robotic arms with 3 being stationary and one being a wearable robot. The first benchmark was AGREE's exoskeleton which is made for upper limb rehabilitation. There are multiple different ways it interacts with the user such as passive-assisted, active-assisted, and active-resistive [1]. The interesting part of this design is a spring pulley antigravity system that helps to minimize torque requirements [1]. The next was a robotic arm by CLEVERarm that is again used for upper limb rehabilitation. This design was focused on compactness and having many degrees of freedom [2]. In comparison to AGREE's it is compact as AGREE's is quite bulky while CLEVERarm is sleek and compact [2]. As well as its compactness, it has eight different degrees of freedom to help the rehabilitation with six being active and two being passive [2]. The third arm was also a robot for rehabilitation of upper limbs by ExoFlex. This was a hybrid exoskeleton which means it has both rigid and soft components [3]. This may not be able to replicate in our design as it would be quite difficult to have an almost crane-like robot that is wearable. The last benchmark was a wearable robot but was not designed to be used for upper limb rehabilitation. The design was made by the client Dr Zachary Lerner to do manual tasks [4]. This will help inform the design to see how to actuate an arm from a wearable device.

3.2 Literature Review

3.2.1 Colin Donnellan: Evolution of Robotic Arms [5]

This was information about how robotic arms have evolved from the very beginning. The point of this was to show the progression of them to get into robotic surgical arms being used. It stops at what is considered modern robotics, so it will need research for more modern robotics. This will apply to the project to help show where to start from if the history is known.

3.2.2 Colin Donnellan: Robotic arm use for upper limb rehabilitation after stroke: A systematic review and meta-analysis [6]

The study was about how upper limb mobility improved with the use of a robotic arm. The report compiles six different studies to get information. It shows that upper limb mobility was improved in stroke survivors with activity in the arm between 30-60 minutes. This will help the project as the goal is to have our design be able to run for 8 hours but knowing that half an hour can improve mobility is helpful.

3.2.3 Colin Donnellan: International Organization for Standardization [7]

These are standards used for human robotic interaction. The standards will help outline the safety to implement while the project is being designed. This will ensure our design meets safety standards.

3.2.4 Colin Donnellan: Investigation of the Mounting Position of a Wearable Robot Arm [8]

This was a report talking about the different spots to mount a robot arm. This helped us understand the difficulties in different mounting positions. The robot that the team is designing has been specified from

the beginning to be at the hip. This will still help the design process to see what can be done and possible challenges that will involve it.

3.2.5 Colin Donnellan: A Review of Robotic Arm Joint Motors and Online Health Monitoring Techniques [9]

The report reviewed commonly used motors for joints in robotic motors. It shows the comparison between several motors to use and how to compare them. This was found before talking to the client Dr Zachary Lerner who then suggested three different motors. Still, this helped explain how to select motors for a robotic arm.

3.2.6 Colin Donnellan: Human upper limb and arm kinematics for robot based rehabilitation [10]

The report is an introduction to kinematics and how it was used to help upper limb rehabilitation. This can be used for the robotic arm that the team will design to help develop an understanding of how to make the arm work. It can be hard using kinematics but may be helpful knowledge to use for inverse kinematics.

3.2.7 Colin Donnellan: Effects of two different robot-assisted arm training on upper limb motor function and kinematics in chronic stroke survivors: A randomized controlled trial [11]

The report is background information on how well robot assisted therapy helps in upper limb rehabilitation in stroke survivors. Shows kinematics as well so that they can improve the team's understanding for future parts of the project. Again, it also shows the improvement made by people using robot assisted therapy.

3.2.8 Kaitlyn Davis: X. Fan et al., A humanoid robot teleoperation approach based on waist–arm coordination | emerald insight [12]

The report describes the control system of humanoid robots that control waist-arm coordination (WAC). It also introduced dual-arm coordination (DAC). The DAC method focuses more on the relationship between a single controller and a manipulator. The WAC method focuses on the motion of both the arm and hip; this method is used to understand the inverse kinematics that may be needed to calculate the velocity.

3.2.9 Kaitlyn Davis: K. Kruthika, B. M. K. Kumar, and S. Lakshminarayanan, “Design and development of a robotic arm | IEEE conference publication | IEEE xplore,” IEEEExplore [13]

This paper provides information about the kinematics of a 5-degree of freedom (DOF) and how they function. It provides the principles of robotic kinematics, MATLAB, and Arduino. There are also different models for the angle configurations and to prove the kinematics of the robotic arm.

3.2.10 Kaitlyn Davis: C. Ochieze, S. Zare, and Y. Sun, “IOPscience,” Progress in Biomedical Engineering [14]

This is a review of biomedical engineering and the exoskeleton systems that they are using for human assistance. It also focuses on the design of wearable robotics; this includes rigid-joint and soft

exoskeletons used in pervasive health. It applies to upper limb kinematics and biomechanics of these rehabilitation devices.

3.2.11 Kaitlyn Davis: M. A. Gull, S. Bai, and T. Bak, “A review on design of upper limb exoskeletons,” MDPI [15]

This report is a review of multiple upper limb exoskeletons used for human-robot interaction, or for neuromuscular rehabilitation. It provides classification and comparisons of multiple exoskeletons. It provides challenges along with some of the systems' pr methods that are needed when designing an exoskeleton for rehabilitation purposes.

3.2.12 Kaitlyn Davis: Comparison of material’s properties for exoskeletons structure | download scientific diagram [16]

This paper provides a list of materials used in an exoskeleton and provides important information such as the pros and cons of each material. It also includes the density, hardness, Youngs modulus, shear modulus, weldability, and machinability of each material.

3.2.13 Kaitlyn Davis: Z.-J. Chen, “Exoskeleton-assisted anthropomorphic movement training for the upper limb after stroke: The EAMT randomized trial | stroke,” AHAJournals [17]

This article analyzes the effects of exoskeletons and physical therapy among stroke patients. Provides figures that relate natural movement, time, and joint angle data, as well as degrees of freedom. this may further our understanding of the mobility of different stroke patients and how to design our exoskeleton.

3.2.14 Kaitlyn Davis: Y. Zhao, H. Wu, M. Zhang, J. Mao, and M. Todoh, “Design methodology of portable upper limb exoskeletons for people with strokes,” Frontiers [18]

This article provides the mobility and portability of an exoskeleton device, along with its uses and what it can do for stroke patients. The article provides examples of the exoskeleton materials, actuation systems, the three different motors (electric, hydraulic, and pneumatic), and different operation modes (assistive, corrective, and resistive). Discomfort and singularity problems are also mentioned as the exoskeleton may face some issues with accidental collisions with adjacent objects.

3.2.15 Caleb Lamca: Ergonomics and Design: A Reference [19]

This design guide for ergonomics highlights the human factors and limitations that engineers need to understand before designing products meant for human interaction. Included is the rationale behind engineering for people but also includes references to anthropometry and how to deisgn most efficiently for your target. Common workplace motions, everyday uses and fatigues, and general design considerations are discussed in this handbook.

3.2.16 Caleb Lamca: Industrial Maintenance and Mechatronics [20]

Chapter 12 is all about belt drives and gear drives, very useful when determining the drivers behind our motor system. The full discusses the in-depth aspects of the industrial maintenance sphere but has a very

relevant correlation to small-scale products such as the robotic arm we are building as a team. The book discusses loads, nominal tolerances, the different applications for different drivers, and all useful information relating to our design space.

3.2.17 Caleb Lamca: Understanding Steel Tube and Pipe Metallurgy [21]

If we use piping, this source provides insight into the strength of piping and how to select the right materials for our desired applications. Also discussed heavily is how hardness influences design decisions. From heat-treat to metallurgic properties, hardness has an impact on which products to use. The article also discusses how to measure and apply this knowledge to various applications.

3.2.18 Caleb Lamca: Fastener Design Manual [22]

This design handbook from NASA discusses various fasteners including rivets, screws, and adjacent products like washers and flare nuts. The team can use this information to influence design decisions and make strategic use of the resources given. This is our only source as a team on fasteners but holds significant importance when thinking of how we will physically build our prototype and eventually the final design.

3.2.19 Caleb Lamca: Mechanisms [23]

This handbook describes kinematics and how they apply to all mechanisms. The team will leverage the in-depth content relating to degrees of freedom and kinematics in the physical design process of our robotic arm. The handbook also dives into motors from AC to air and hydraulics, useful in determining how our system will operate and what drivers will be the most beneficial.

3.2.20 Caleb Lamca: Handbook on Polymer Selection for Engineering [24]

Polymer selections, something we should have a source for if we use polymers. We likely will, as polymers are widely used in biomedical applications, and we could use their high strength and low weight properties in our own design. This polymer selection handbook will be useful in the selection criteria behind each design choice we make in this design sphere.

3.2.21 Caleb Lamca: Metal Strength Chart - A Pro Guide 2025 [25]

This article provides hard data and theory behind metal strength and applications. All types of strength are discussed, from shear to bending. If our team decides to use metal in our designs, we will use this article to influence certain design decisions to ensure we have the most robust design for our given application.

3.2.22 Joel Gisleskog: Series Elastic Actuators [26]

Pratt and Williamson introduce series elastic actuators and explain why lightweight, efficient designs are needed for better torque control in powered exoskeletons.

3.2.23 Joel Gisleskog: Quasi-Direct-Drive Actuation for Shoulder Exoskeletons [27]

Yu, Chen and Liu discuss quasi-direct-drive actuation, highlighting how some bandwidth is traded off to improve compliance and control in shoulder exoskeletons.

3.2.24 Joel Gisleskog: Gravity Compensation of an Upper Extremity Exoskeleton [28]

Moubarak et al. compare passive and active gravity compensation methods, giving useful insight for early design choices in how to support arm weight.

3.2.25 Joel Gisleskog: Human Arm Weight Compensation in Rehabilitation Robotics [29]

Just et al. compare three different gravity compensation methods and show their effectiveness, which can help guide the control approach for our own system.

3.2.26 Joel Gisleskog: Gravity Compensation of an Exoskeleton Joint Using Constant-Force Springs [30]

Hill et al. show how constant-force springs can lower the torque requirements at exoskeleton joints, improving overall mechanical efficiency.

3.2.27 Joel Gisleskog: Model-Based Control for Exoskeletons with Series Elastic Actuators [31]

Vantilt et al. describe the kinematic and dynamic modelling steps used in exoskeletons with series elastic actuators, which will be useful for our own model development.

3.2.28 Joel Gisleskog: Standard Terminology for Exoskeletons and Exosuits [32]

ASTM International defines the official terminology for exoskeletons and exosuits, helping keep our project language and reports consistent.

3.2.29 Joel Gisleskog: ISO 13485:2016 – Medical Device Regulations [33]

Outlines the regulatory and quality management requirements for medical devices, providing a framework to ensure our design meets safety and compliance standards

3.2.30 Cole Pace: Survey on Main Drive Methods Used in Humanoid Robotic Upper Limbs [34]

This report outlined the main driving mechanisms used in robotic upper limbs, such as direct drive, tendon drive, and transmission systems. It helped the team understand the trade-offs between torque output, back drivability, and efficiency when determining which actuation method would best fit the wearable arm's design goals.

3.2.31 Cole Pace: Upper Limb Soft Robotic Wearable Devices: A Systematic Review [35]

This study reviewed soft robotic exosuits and wearable upper limb devices designed to restore motion and assist movement. It helped demonstrate the importance of lightweight and flexible materials for user comfort, guiding material and design choices for the prototype.

3.2.32 Cole Pace: Human Weight Compensation With a Backdrivable Upper-Limb Exoskeleton [36]

This paper discussed weight compensation control strategies for backdrivable exoskeletons. It provided insight into how gravity-compensation algorithms can reduce user fatigue and improve safety when supporting the weight of the arm.

3.2.33 Cole Pace: 3D Printing Continuous Fiber Reinforced Polymers [37]

This article covered the manufacturing process and benefits of printing parts with continuous fiber reinforcement. It supported design decisions on how to fabricate lightweight, high-strength parts for the robotic arm using fiber-reinforced materials.

3.2.34 Cole Pace: Robots and Robotic Devices — Safety Requirements for Personal Care Robots [38]

This ISO standard defines safety protocols for physical assistant robots that interact directly with humans. It ensures that the team’s design process follows established international safety guidelines for wearable robotics and physical human–robot interaction.

3.2.35 Cole Pace: A Simplified Inverse Dynamics Modelling Method for a Novel Rehabilitation Exoskeleton [39]

This report provided a simplified inverse dynamics model for calculating the torque required at each joint of a rehabilitation exoskeleton. It helped determine the necessary motor output and control strategies for the elbow and shoulder joints in the team’s design.

3.2.36 Cole Pace: Upper Limb Motor Impairment After Stroke [40]

This study reviewed common upper-limb impairments experienced by stroke survivors, including weakness, spasticity, and loss of coordination. It justified the need for an assistive robotic arm by outlining how gravity-compensation and motion assistance can improve functional recovery.

3.3 **Mathematical Modeling**

3.3.1 **Battery Capacity for One Motor - Colin Donnellan**

Dr Zachary Lerner gave the team three motors to possibly consider for the project. The team decided to use those motors in our calculations as Dr Lerner is a client and knows more about wearable robotics. The motors given were AK40-10 KV170, AK45-10 KV75, and the AK45-36, which are all suitable for humanoid robotic joints. Using the product comparison from the website, the next step was to find the capacity needed to power the motors.

$$Capacity = \frac{Rated\ Power}{Rated\ Voltage} \cdot 8\ Hours$$

(1)

AK40-10: 20 Ah

AK45-10: 13 Ah

AK45-36: 11 Ah

The rated power and rated voltage were used as those are the values for each motor that are at a safe usage to not overheat or damage the motor. It was next multiplied by eight hours as that is the time that the group wants the product to last. Lastly, the equation above only gives the capacity of one motor and the design that will be used will have two motors, so the found value will need to be doubled to find the true capacity needed.

3.3.2 Cross Sectional Geometric Selections – Caleb Lamca

One important aspect of the design process is determining the beam geometry, specifically the cross-sectional geometry. For this application, there were two leading ideas; a rectangular tube and a circular tube. Both of these designs are easy to find cheap prototype alternatives, exist in abundance in the open market, and can be 3D printed with relative ease [21]. For the remainder of the calculations in this section, we will focus on these two designs. When comparing the cross-sectional geometry, we use equations for the Moment of Inertia, which are crucial in determining the maximum stress in each beam in comparison to the maximum allowable stress in our design as a whole.

$$\sigma_{max, c} = \frac{(M_{max} \cdot c)}{I_c} = 15.4[MPa]$$

$$\sigma_{max, s} = \frac{(M_{max} \cdot c)}{I_s} = 69.4[MPa]$$

As we can clearly see from equations 2 and 3, the circular cross-section carries a significantly lower stress, roughly 4 times less. This lower stress will allow the team to have a higher factor of safety, which is important when designing a medial-adjacent product with dynamic forces. We can also extract that the moment of inertia directly determines the output for maximum stress per beam. A higher moment of inertia will contribute to lower maximum stress.

$$I_c = \frac{\pi}{64}(D^4 - d^4) = 9 \cdot 10^{-6}[m^{-4}]$$

$$I_s = \frac{HW^3 - hw^3}{12} = 2 \cdot 10^{-6}[m^{-4}]$$

Equations 4 and 5 show this principle. The circular cross-section has a much higher moment of inertia and will therefore contribute to a lower stress in any beam it will be utilized. As long as the geometries for the square tubing and circular tubing are comparable- as they would both need to have similar sizes to fit the same application, the circular cross-section will always have the higher moment of inertia. The team used these calculations and principles to determine that the circular cross-sectional geometry will be best suited for our design applications. Along with other factors, such as cost, ease of acquisition, ease of prototyping, etc.

3.3.3 Joel

Part of the design requirement is for the clients arm to be able to comfortably rest by their side, I would like to work out what angular velocity the robotic links would have to move to go from resting to extended in front of the client in a specific amount of time. To figure this out, I first needed to know what angles the robotic links would start at rest. To do this, use the Pythagoras

theorem.

Now we have the co-ordinates of the links at the rest position; to work out the angular velocity we must pick a time for the arm to reach the desired position in. I measured myself naturally lifting my arm out to the fully extended position multiple times and got a avg of 1.28s. I assumed that for the desired position the robotics arm must both be at a angle of 45 degrees.

Here are the final co-ordinates at the end position. The links have to turn through a unique angle each, so the links have to move at different angular velocities.

So therefore, the maximum required velocity is 1.6171 rad/s. This is helpful as this informs our decision when picking motors based on the required torque.

3.3.4 Cole

Using the angular velocity from the previous calculations, the torque at both the hip and the elbow was able to be calculated for both a direct drive and a remote transmission system. The following equations are for the transmission design.

$$\underline{\text{Hip:}} \tau_1 = g \left(m_1 r_1 + m_2 (L_1 + r_2) + m_p (L_1 + L_2) \right) + \alpha_1 (m_1 r_1^2 + m_2 (L_2 + r_2)^2 + m_p (L_1 + L_2)^2) \tau_1 = 6.78 N \cdot m$$

$$\tau_1 = 6.78 N \cdot m$$

$$\tau_{1S} = 10 N \cdot m$$

Elbow:

$$\tau_2 = g (m_2 r_2 + m_p L_2) + \alpha_2 (m_2 r_2^2 + m_p L_2^2)$$

$$\tau_2 = 2.94 N \cdot m$$

$$\tau_{2S} = 4.5 N \cdot m$$

The next equation is for the direct drive system.

$$\underline{\text{Hip:}} \tau_1 = g \left(m_1 r_1 + (m_2 + m_{m2}) (L_1 + r_2) + m_p (L_1 + L_2) \right) + \alpha_1 (m_1 r_1^2 + m_2 (L_2 + r_2)^2 + m_p (L_1 + L_2)^2) \tau_1 = 7.65 \sim N \cdot m$$

$$\tau_{1S} = 11.5 N \cdot m$$

With these torque values, we were able to select the motor that can produce this torque.

3.3.5 Velocity for Shoulder Flexion at the Elbow - Kaitlyn Davis

Velocity of the arm at the elbow when the shoulder is undergoing forward flexion, where the arm starts from hanging straight down at 0 degrees and moves upward to a 90-degree angle. Here, the velocity of the arm at the elbow is observed.

According to research, the average shoulder to elbow length is about 330mm (13in) in an adult.

Average angular velocity equations: $w_{avg} = \frac{\text{delta theta}}{\text{Time } t}$

To reach 90 degrees from shoulder flexion (delta theta = 90 degrees) it took a time of 1.28 seconds. We plugged our known values into the equation below.

$$w_{avg} = \frac{\text{delta theta}}{\text{Time } t} = \frac{90\text{degrees} \left(\frac{\pi}{180}\right)}{1.28\text{s}} = 1.227 \frac{\text{rad}}{\text{s}}$$

The average angular velocity of the arm from 0 to 90 degrees is $1.227 \frac{\text{rad}}{\text{s}}$.

The linear velocity of the elbow can be solved by using the equation below. For the radius r value, 330mm = 0.33m is used, because the velocity of the elbow is being solved.

$$v = w_{avg} * r = 1.227 \frac{\text{rad}}{\text{s}} * 0.33 \text{ m} = 0.405 \frac{\text{m}}{\text{s}}$$

Our results show that the velocity of our arm design needs to move around $0.405 \frac{\text{m}}{\text{s}}$ for safety and comfort when the device needs to move upward and downward.

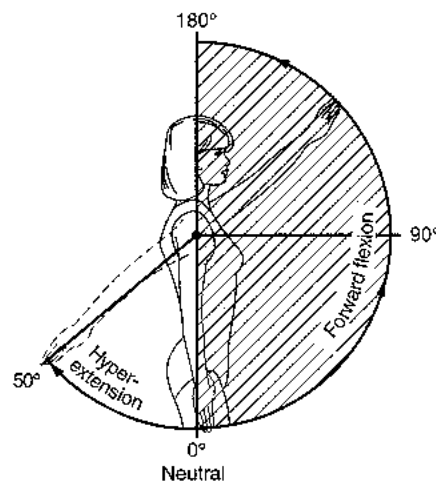

Figure 2: Anthropometry of Range of Motion

4 Design Concepts

4.1 Functional Decomposition

Figure 2 depicts the functional decomposition the team will use as a reference for the remainder of this project. Through this chart, we will be able to easily identify the next step at each stage in design and determine where to direct the most attention. This chart will act as an outline to ensure we have delivered every aspect of our design for each project deliverable.

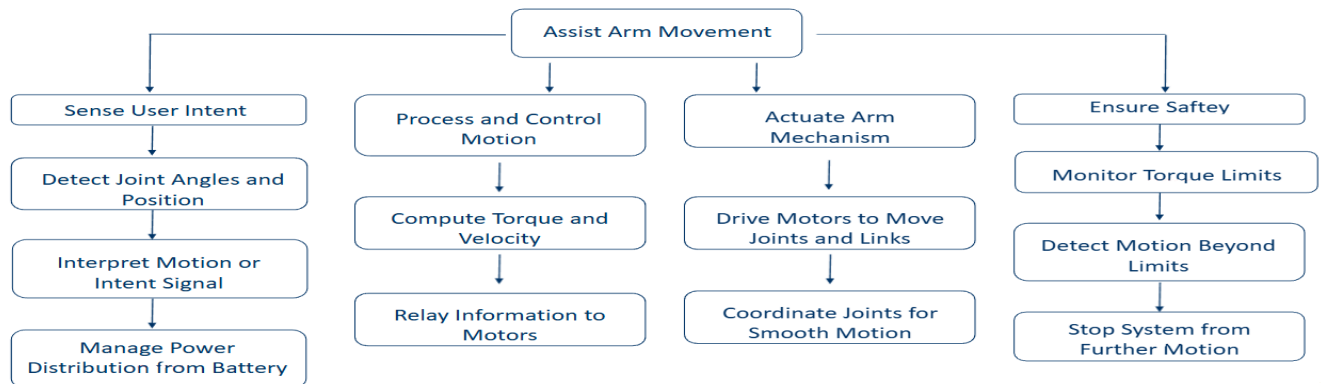

Figure 3: Functional Decomposition

The functional decomposition is especially important for our project as there are many elements that are dependent on one another. Understanding which components and features affect others before the extensive design and prototype phases will streamline our processes and limit fatigue and frustration.

4.2 Concept Generation

The team decided on three major criteria to evaluate the design of our device. The three major criteria were the motors, joints, and the link geometry. To evaluate each motor, the team considered rated voltage (V), rated power (W), rated torque (Nm), rated current (A), rated speed (RPM), peak torque (Nm), peak current (A), No-load speed (RPM), reduction ratio, weight (G), size (diameter * length), driver board, and encoder.

For motor selection, the team was given three different motors by the client to evaluate.

- AK40-10 KV170
 - Pros: Lightest weighing motor and highest rated speed.
 - Cons: Lowest torque and won't be able to provide the torque needed for our device.
- A45-10 KV75
 - Pros: Lightweight, and good rated speed
 - Cons: Low torque will not be able to provide the torque needed for our device.
- AK45-36 KV80
 - Pros: Handles needed torque for each joint in both transmission and direct drive.

- Cons: Heaviest option which will increase device weight and has the lowest rated speed.

For joints, the team considered the degrees of freedom (DOF) for the device and whether a certain joint may be suitable to achieve the wanted DOF. The team determined that the top three options were ring joints, ball joints, and revolute joints.

- Ring joint (2 DOF)
 - Pros: Finer movement of the hand / arm is allowed.
 - Cons: transmitting power to two different axis increases cost and complexity.
- Ball joint (3 DOF)
 - Pros: Smoother movement of the arm is allowed.
 - Cons: Requires three motors for each DOF
- Revolute joint (1 DOF)
 - Pros: Simple transmission and requires only one motor.
 - Cons: Limited DOF causes less smooth movement and motion.

For Link geometry, the team had considered simple cross-sectional geometry links, to where they would be evaluated. It was decided that the best simple options were a hollow rectangular cross-section and a hollow circular cross-section.

- Hollow Rectangular
 - Pros: Strong directional stiffness and low weight.
 - Cons: Weak torsion and off axis bending.
- Hollow Circular
 - Pros: Resists twisting
 - Cons: Less stiff per unit weight in one direction

4.3 Selection Criteria

The team selected motor, link geometry, and the joints for how the design will come together. Each of the parts had its own criteria to find out how each part is selected.

The first was the motor that the design will use. The three motors that Dr. Lerner gave us were evaluated by how the motors can handle the torques that were calculated above.

Model	Rated Voltage (V)	Rated Power (W)	Rated Torque (Nm)	Rated Current (A)	Rated Speed (RPM)	Peak Torque (Nm)	Peak Current (A)	No-load Speed (RPM)	Reduction Ratio	Weight (G)	Size (diameter *length) MM	Driver Board	Encoder
AK45-36 KV80	24	33	8	2	40	24	6.5	52	36:1	340	φ55*54	Yes	Single
AK45-10 KV75	24	39	2.5	2.1	150	7	5	180	10:1	260	φ53*43	Yes	Single
AK40-10 KV170	24	59	1.3	2.7	370	4.1	7.3	435	10:1	200	φ53*37	Yes	Single

Figure 4: Product Comparison

The motor needs to be able to withstand 10 to 11.5 Nm so that the device can hold the arm up. The peak

torque would need to have that requirement as those were the peak torques calculated. From those requirements needed, the motor selected was AK45-36.

The next was the link geometry for how to have the design work. This was found as deciding to be between a rectangular or circular cross section. Deciding between these two was calculated by seeing which area had better bending stress, which can be seen in the modeling section. From that calculation, the cross-sectional area chosen was circular as it can withstand better bending stress.

The last criteria that were needed for the joints and how they will connect with each other. The joint selection that was chosen was a revolute joint. The revolute joint was chosen because of its ability to get the movement that is wanted as well as at the time being there are two modes of actuation one being direct drive and one being transmission drive. For the transmission drive it would need cables and would get in the way of other joints.

4.4 Concept Selection

The team developed two different designs to be submitted to our project sponsor and client, Dr. Lerner. These two designs include a direct drive system and a transmission system. The designs share componentry and end function, but the methods for delivering the project tasks vary slightly. Our selection criteria for each design includes comfort, complexity of design, range of motion, ease of use for the user, and safety in ascending order from least to greatest concern. As mentioned previously, the two designs share striking resemblances and therefore the selection outcome will be equal across multiple criteria.

		Direct Drive (1)	Transmission (2)
--	--	------------------	------------------



			
Comfort	1	+	+
Complexity	2	+	-
Range of Motion	3	+	+
Ease of Use	4	+	+
Safety	5	+	-
Σ		15	8

Table 1: Decision Matrix

This decision matrix highlights the two main designs, with all the previously selected components found through calculation. The same motor (AK45-36), joints (Revolute), and elbow support are used across both designs. The differences between these two designs lie in the power delivery system. A direct drive system has a motor at each joint directly supplying power, while the transmission system has two motors at the hip providing power directly to one joint and sending power via cable to the other joint. The transmission system

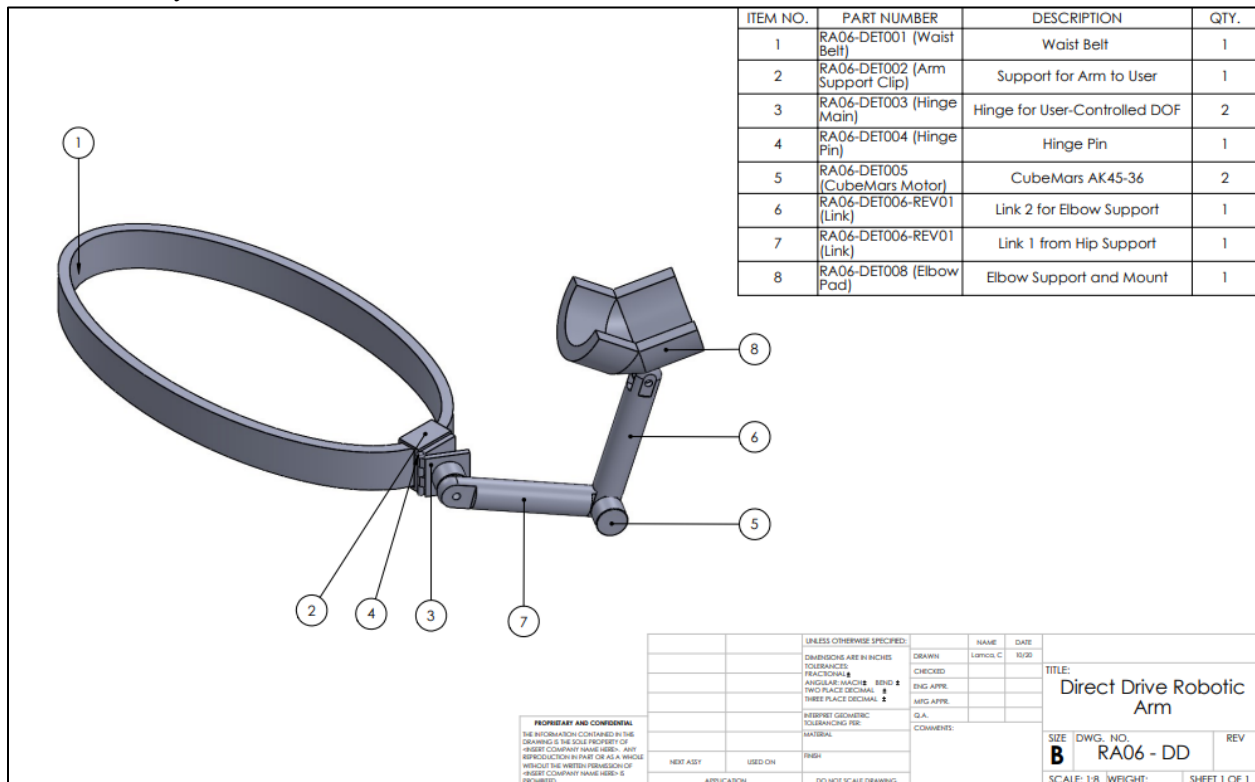

Figure 5: CAD Model with Bill of Materials

Figure 5 shows the most recent CAD model. The model shown is the transmission design as it received the highest score in the concept selection. The main components are listed in the Bill of Materials,

including the individual links, waist belt, revolute joints, elbow pad, and motors sourced from CubeMars.

5 CONCLUSIONS

The project is to develop a waist mounted exoskeleton to help in the rehabilitation process for upper limb mobility for stroke survivors. Upper limb mobility can be severely restricted for people who have had strokes, so the exoskeleton will be gravity assisted in helping regain mobility. The report describes the team's research and the first steps into starting this project. With these findings, the team will decide on parts and will start designing and prototyping.

6 REFERENCES

- [1] S. D. Gasperina *et al.*, “AGREE: A compliant-controlled upper-limb exoskeleton for physical rehabilitation of neurological patients,” *IEEE Transactions on Medical Robotics and Bionics*, pp. 1–1, 2023, doi: <https://doi.org/10.1109/tmrb.2023.3239888>.
- [2] R. Soltani-Zarrin, Amin Zeiaee, A. Eib, Reza Langari, N. Robson, and Reza Langari, “TAMU CLEVERarm: A novel exoskeleton for rehabilitation of upper limb impairments,” Nov. 2017, doi: <https://doi.org/10.1109/werob.2017.8383844>.
- [3] I. M. Alguacil-Diego *et al.*, “Validation of a Hybrid Exoskeleton for Upper Limb Rehabilitation. A Preliminary Study,” *Sensors*, vol. 21, no. 21, pp. 7342–7342, Nov. 2021, doi: <https://doi.org/10.3390/s21217342>.
- [4] D. Colley, C. D. Bowersock, and Z. F. Lerner, “A Lightweight Powered Elbow Exoskeleton for Manual Handling Tasks,” *IEEE Transactions on Medical Robotics and Bionics*, vol. 6, no. 4, pp. 1627–1636, Sep. 2024, doi: <https://doi.org/10.1109/tmrb.2024.3464690>.
- [5] M. E. Moran, “Evolution of robotic arms,” *Journal of Robotic Surgery*, vol. 1, no. 2, pp. 103–111, May 2007, doi: <https://doi.org/10.1007/s11701-006-0002-x>.
- [6] B.-O. Lee, Ita Daryanti Saragih, and Sakti Oktaria Batubara, “Robotic arm use for upper limb rehabilitation after stroke: A systematic review and meta-analysis,” vol. 39, no. 5, pp. 435–445, Mar. 2023, doi: <https://doi.org/10.1002/kjm2.12679>.
- [7] ISO - International Organization for Standardization, “ISO/TS 15066:2016,” *ISO*, Mar. 08, 2016. <https://www.iso.org/standard/62996.html>
- [8] A. Kojima, D. T. Tran, and J.-H. Lee, “Investigation of the Mounting Position of a Wearable Robot Arm,” *Robotics*, vol. 11, no. 1, p. 19, Feb. 2022, doi: <https://doi.org/10.3390/robotics11010019>.
- [9] M. Y. Metwly, C. L. Clark, J. He, and B. Xie, “A Review of Robotic Arm Joint Motors and Online Health Monitoring Techniques,” *IEEE Access*, pp. 1–1, Jan. 2024, doi: <https://doi.org/10.1109/access.2024.3447573>.
- [10] S. Parasuraman, Kee Chew Yee, and Arif Oyong, “Human upper limb and arm kinematics for robot based rehabilitation,” Jul. 2009, doi: <https://doi.org/10.1109/aim.2009.5229906>.
- [11] K.-H. Cho and W.-K. Song, “Effects of two different robot-assisted arm training on upper limb motor function and kinematics in chronic stroke survivors: A randomized controlled trial,” *Topics in Stroke Rehabilitation*, pp. 1–10, Aug. 2020, doi: <https://doi.org/10.1080/10749357.2020.1804699>.
- [12] X. Fan *et al.*, A humanoid robot teleoperation approach based on waist–arm coordination | emerald insight, doi: <https://www.emerald.com/insight/content/doi/10.1108/IR-12-2022-0306/full/html>

- [13] K. Kruthika, B. M. K. Kumar, and S. Lakshminarayanan, "Design and development of a robotic arm | IEEE conference publication | IEEE xplore," IEEE Xplore, doi: <https://ieeexplore.ieee.org/abstract/document/8053274/>
- [14] C. Ochieze, S. Zare, and Y. Sun, "IOPscience," Progress in Biomedical Engineering, doi: https://iopscience.iop.org/article/10.1088/2516-1091/acc70a/meta?utm_source
- [15] M. A. Gull, S. Bai, and T. Bak, "A review on design of upper limb exoskeletons," MDPI, doi: https://www.mdpi.com/2218-6581/9/1/16?utm_source
- [16] Comparison of material's properties for exoskeletons structure | downloaded scientific diagram, doi: https://www.researchgate.net/figure/Comparison-of-materials-properties-for-exoskeletons-structure_tbl4_365212324
- [17] Z.-J. Chen, "Exoskeleton-assisted anthropomorphic movement training for the upper limb after stroke: The EAMT randomized trial | stroke," AHAJournals, doi: <https://www.ahajournals.org/doi/10.1161/STROKEAHA.122.041480>
- [18] Y. Zhao, H. Wu, M. Zhang, J. Mao, and M. Todoh, "Design methodology of portable upper limb exoskeletons for people with strokes," Frontiers, doi: https://www.frontiersin.org/journals/neuroscience/articles/10.3389/fnins.2023.1128332/full?utm_source
- [19] S. Openshaw, E. Taylor, G. Minder, W. Witherow, T. J. Long, and M. Ford, *Ergonomics and Design: A Reference Guide*, Allsteel Inc., Muscatine, IA, April 2006. [Online]. Available: <https://ehs.oregonstate.edu/sites/ehs.oregonstate.edu/files/pdf/ergo/ergonomicsanddesignreferenceguidewhitepaper.pdf> [Environmental Health and Safety](#)
- [20] G. R. Ballee, *Industrial Maintenance and Mechatronics*, 2nd ed., Goodheart-Willcox Company, Inc., Tinley Park, IL, 2022. ISBN: 978-1637767115. [Chapter 12]. [G-W+1](#)
- [21] "Understanding Steel Tube and Pipe Metallurgy," *The Fabricator*, Jul. 18, 2019. [Online]. Available: <https://www.thefabricator.com/tubepipejournal/article/tubepipeproduction/understanding-steel-tube-and-pipe-metallurgy> [The Fabricator](#)
- [22] R. T. Barrett, *Fastener Design Manual*, NASA Reference Publication 1228, Lewis Research Center, Cleveland, OH, USA, Mar. 1990. [Online]. Available: <https://ntrs.nasa.gov/api/citations/19900009424/downloads/19900009424.pdf> [NASA Technical Reports Server](#)
- [23] *Mechanisms*, Lunnyax (Wordpress.com), Jun. 2014. [Online]. Available: <https://lunnyax.wordpress.com/wp-content/uploads/2014/06/mechanisms.pdf> [lunnyax's Blog](#)
- [24] *Handbook on Polymer Selection for Engineering*, Google Books. [Online]. Available: <https://books.google.com/books?hl=en&lr=&id=-MB2DhLQ-q0C&oi=fnd&pg=PA421&dq=handbook+on+polymer+selection+for+engineering> ... [Google Books](#)

- [25] “Metal Strength Chart - A Pro Guide 2025,” PartMFG, 2025. [Online]. Available: <https://www.partmfg.com/metal-strength-chart-a-pro-guide-2025/partmfg.com>
- [26] G. A. Pratt and M. M. Williamson, “Series elastic actuators,” in *Proc. IEEE/RSJ Int. Conf. Intelligent Robots and Systems (IROS)*, 1995, pp. 399–406, doi: <https://doi.org/10.1109/IROS.1995.525827>
- [27] P. Yu, W. Chen, and C. Liu, “Quasi-direct-drive actuation for shoulder exoskeletons: Design and evaluation,” *IEEE/ASME Trans. Mechatronics*, vol. 25, no. 5, pp. 2410–2421, 2020, doi: <https://doi.org/10.1109/TMECH.2020.2995134>
- [28] E. Moubarak, K. Pham, R. Moreau, and E. Redarce, “Gravity compensation of an upper extremity exoskeleton,” in *Proc. IEEE EMBC*, 2010, pp. 4479–4482, doi: <https://doi.org/10.1109/IEMBS.2010.5626036>
- [29] F. Just *et al.*, “Human arm weight compensation in rehabilitation robotics: efficacy of three distinct methods,” *J. NeuroEngineering & Rehabilitation*, vol. 17, Art. 14, 2020, doi: <https://doi.org/10.1186/s12984-020-0644-3>
- [30] C. Hill *et al.*, “Gravity Compensation of an Exoskeleton Joint Using Constant-Force Springs,” in *Proc. IEEE Int. Conf. Rehabilitation Robotics (ICORR)*, 2019, pp. 1032–1037, doi: <https://doi.org/10.1109/ICORR.2019.8779422>
- [31] J. Vantilt *et al.*, “Model-based control for exoskeletons with series elastic actuators,” *J. NeuroEngineering & Rehabilitation*, vol. 16, Art. 100, 2019, doi: <https://doi.org/10.1186/s12984-019-0526-8>
- [32] ASTM International, *F3323-21: Standard Terminology for Exoskeletons and Exosuits*, 2021. Available: <https://www.astm.org/f3323-21.html>
- [33] ISO, *ISO 13485:2016 - Medical devices — Quality management systems — Requirements for regulatory purposes*, 2016. [Online]. Available: <https://www.iso.org/standard/59752.html>
- [34] Y. Wang, W. Li, S. Togo, H. Yokoi, and Y. Jiang, “Survey on Main Drive Methods Used in Humanoid Robotic Upper Limbs,” *Cyborg and Bionic Systems*, vol. 2021, pp. 1–12, Jun. 2021, doi: <https://doi.org/10.34133/2021/9817487>
- [35] E. Bardi, M. Gandolla, F. Braghin, F. Resta, A. L. G. Pedrocchi, and E. Ambrosini, “Upper limb soft robotic wearable devices: a systematic review,” *Journal of NeuroEngineering and Rehabilitation*, vol. 19, no. 1, Aug. 2022, doi: <https://doi.org/10.1186/s12984-022-01065-9>
- [36] D. Verdel, S. Bastide, N. Vignais, O. Bruneau, and B. Berret, “Human Weight Compensation With a Backdrivable Upper-Limb Exoskeleton: Identification and Control,” *Frontiers in Bioengineering and Biotechnology*, vol. 9, Jan. 2022, doi: <https://doi.org/10.3389/fbioe.2021.796864>.
- [37] H. Zheng *et al.*, “3D Printing Continuous Fiber Reinforced Polymers: A Review of Material Selection, Process, and Mechanics-Function Integration for Targeted Applications,” *Polymers*, vol. 17,

no. 12, pp. 1601–1601, Jun. 2025, doi: <https://doi.org/10.3390/polym17121601>

[38] ISO, "Robots and robotic devices — Safety requirements for personal care robots," ISO 13482:2014, International Organization for Standardization, Geneva, Switzerland, 2014. [Online]. Available: <https://www.iso.org/standard/53820.html>

[39] Q. Fang, G. Li, T. Xu, J. Zhao, H. Cai, and Y. Zhu, "A Simplified Inverse Dynamics Modelling Method for a Novel Rehabilitation Exoskeleton with Parallel Joints and Its Application to Trajectory Tracking," *Mathematical Problems in Engineering*, vol. 2019, Article ID 4602035, 10 pages, 2019, doi: 10.1155/2019/4602035. [Online]. Available: <https://pdfs.semanticscholar.org/637d/9c65e0053fe6b7fb3adddf370617520c7cd3.pdf>

[40] P. Raghavan, "Upper Limb Motor Impairment After Stroke," *Physical Medicine and Rehabilitation Clinics of North America*, vol. 26, no. 4, pp. 599–610, Nov. 2015, doi: <https://doi.org/10.1016/j.pmr.2015.06.008>